

FEATURES

The diagnostic function of the PIM enables safe operation of pumps and systems. Due to the continuous monitoring of pumps and machines the sensor can be perfectly integrated in the condition-based maintenance concepts. Problems with slides or valves lead to mechanical destruction of pumps. Early diagnosis of faults on pumps, drastically reduce maintenance costs. With the use of the PIM sensor, maintenance can be planned, the reliability of pump systems is improved, and machine uptime is increased. Expensive consequential damage caused by the failure of pumps is avoided and, notably, environmental stress (sometimes associated with extreme consequential costs) is prevented. By integrating maintenance into a real-time-maintenance concept it can be implemented at the right time, in the right place, using the right material and staff.

Operation – In addition to monitoring pressure, abnormal pressure patterns are detected. Such conditions as circulation, water hammer, and loss of one phase are quickly detected via a digital output. The operator can be notified immediately via telemetry.

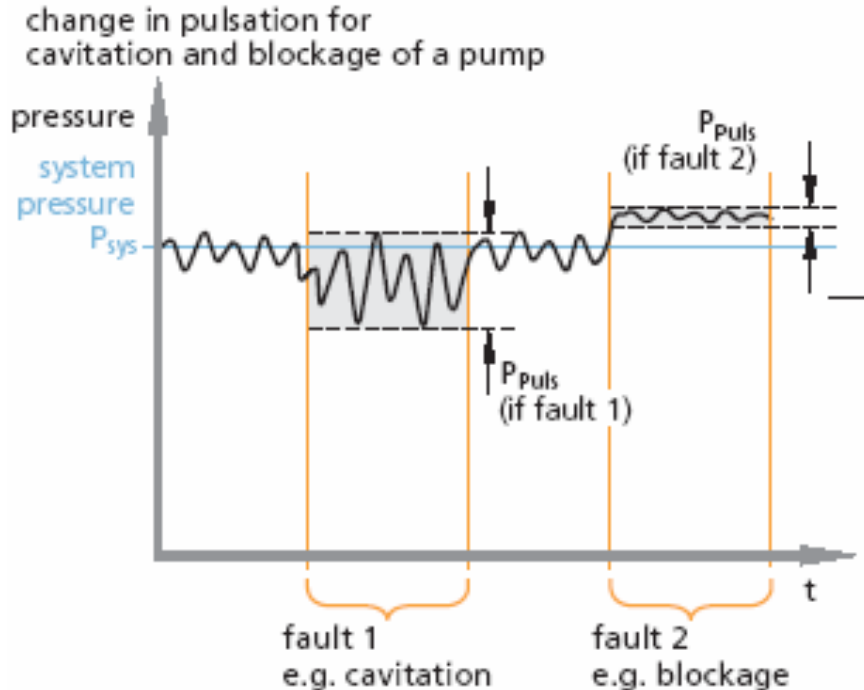

Technical data pump diagnostic sensor

| | | | | |
|---|---|--------|----------------------|--------|
| Application | Liquids | | | |
| Electrical design | DC | | | |
| Type of connection | 3-wire | | | |
| Output function | Aseptoflex adapter thread | | G 1 A adapter thread | |
| Pressure range [bar] | 25 | 10 | 25 | 10 |
| Order no. | PIM093 | PIM094 | PIM693 | PIM694 |
| Operating voltage [V] | 18...32 DC | | | |
| Current consumption [mA] | < 50 | | | |
| Current rating [mA] | 250 | | | |
| Analogue output for static pressure (scalable) [mA] | 4...20 | | | |
| Binary diagnostic output for dynamic pressure | yes | | | |
| Medium temperature [°C] | -25...125 (145 max. 1 h) | | | |
| Accuracy / deviation [in % of the span] | | | | |
| Deviation of the characteristics | < ± 0.2 | | | |
| Linearity | < ± 0.15 | | | |
| Hysteresis | < ± 0.15 | | | |
| Repeatability | < ± 0.1 | | | |
| Long-term stability | < ± 0.1 | | | |
| Temperature coefficient over the whole temperature range: Greatest TEMPCO of zero | < ± 0.15 | | | |
| Greatest TEMPCO of the span | < ± 0.1 | | | |
| Materials wetted parts | high-grade stainless steel (316S12); ceramics (99.9% Al ₂ O ₃); PTFE | | | |
| Protection rating | IP 67 / IP 69 K | | | |
| Connection | M12 connector | | | |

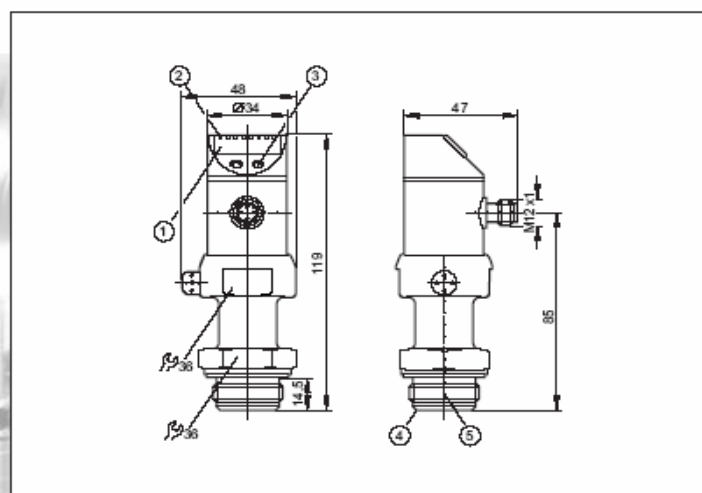

- 1 = 4-digit alphanumeric display
- 2 = LEDs (display unit / switching status)
- 3 = Programming button
- 4 = Aseptoflex sealing edge
- 5 = Aseptoflex thread

Sockets

| Description | Order no. |
|-------------------------------------|-----------|
| 5 m PVC, M12 angled, without LED | E10700 |
| 10 m PVC, M12 angled, without LED | E10701 |
| 5 m PVC, M12 straight, without LED | E10662 |
| 10 m PVC, M12 straight, without LED | E10663 |

Accessories (selection)

| Description | Order no. |
|---|-----------|
| Aseptoflex adapter* clamp 1 - 1.5" (DN25-40) | E33001 |
| Aseptoflex adapter* clamp 2" (DN50) | E33002 |
| Welding adapter Ø 50 mm high-grade stainless steel (316S12) / O-ring FPM (Viton) | E30052 |
| Welding adapter G1 - Ø 50 mm high-grade stainless steel (316S12) | E30013 |
| Welding adapter G1 - Ø 50 mm, high-grade stainless steel (316S12) / O-ring Viton / EPDM | E30072 |
| PC/EP5 programming interface set | ZZ0050 |

*Further aseptoflex adapters on request